

ROTOBALE COMPACTION SOLUTIONS INC.

7232 Arthur Road #5 West
 Kenilworth, ON N0G 2E0
 T: (519) 323.3673
 TF: (800) 565.8027
 F: (519) 323.3816
 www.rotobalecompaction.ca

Stationary Compactors & Containers

BY ROTOBALE COMPACTION SOLUTIONS INC.



MODEL "4260 & C-SERIES" STATIONARY COMPACTOR GENERAL SPECIFICATIONS

		Dual Cylinder	Single Cylinder	Single Cylinder	Single Cylinder
		4260	C-16	C-22	C-26
Dimensions					
Overall Length	A	83"	130"	168"	228"
Overall Height	B	55"	55"	55"	55"
Body Width	C	77"	77"	77"	77"
Arm Clamp Width	D	110"	110"	110"	110"
Chargebox WxLxD	ExFxG	60"x43"x28"	60"x43"x28"	60"x60"x28"	60"x90"x28"
Feed Height	H	43"	43"	43"	43"
Performance Characteristics					
Operational Compaction Force		63,600 lbs	56,520 lbs	56,520 lbs	56,520 lbs
Maximum Compaction Force		76,320 lbs	67,824 lbs	67,824 lbs	67,824 lbs
Ram Penetration (within container)		16"	14"	18"	18"
Electrical / Hydraulic Specifications					
Electrical Motor		10 / 5 HP	10 / 5 HP	10 / 5 HP	10 / 5 HP
Pump Capacity		10.8 / 5.4 gpm	10.8 / 5.4 gpm	10.8 / 5.4 gpm	10.8 / 5.4 gpm
Cycle Time		45s / 90s	45s / 90s	60s / 120s	70s / 140s
Voltage		To suit customers needs			
Electrical Control Voltage		110VAC	110VAC	110VAC	110VAC
Normal Pressure		2000 psi	2000 psi	2000 psi	2000 psi
Maximum Pressure		2400 psi	2400 psi	2400 psi	2400 psi
Hydraulic Cylinder		(2) 4.5"	(1) 6"	(1) 6"	(1) 6"

SPECIFICATIONS SUBJECT TO CHANGE WITHOUT NOTICE TO ACCOMMODATE EQUIPMENT IMPROVEMENTS



Benefits:

- **Reduce haulage costs** as Rotobale's line of Stationary Compactors pack more than the industry standard.
- **Maximum penetration** promotes a cleaner environment as less mess when the container is disengaged.
- **Reduce material handling costs** as large loading chamber is ideal for oversized materials.
- **A large assortment** of standard or custom designed hoppers can be adapted to suit any waste removal application
- **Adaptation** to walk-out weather enclosures, conveyors and hydraulic dumpers are just a few examples that illustrate the versatility of this compaction system.
- **A wide range** of receiver containers are available up to 50 cubic yard capacity to maximize loads and reduce haulage costs.



ROTOBALE COMPACTION SOLUTIONS INC.

Rotobale Stationary Compactors & Containers

Proud Canadian Manufacturer Since 1968

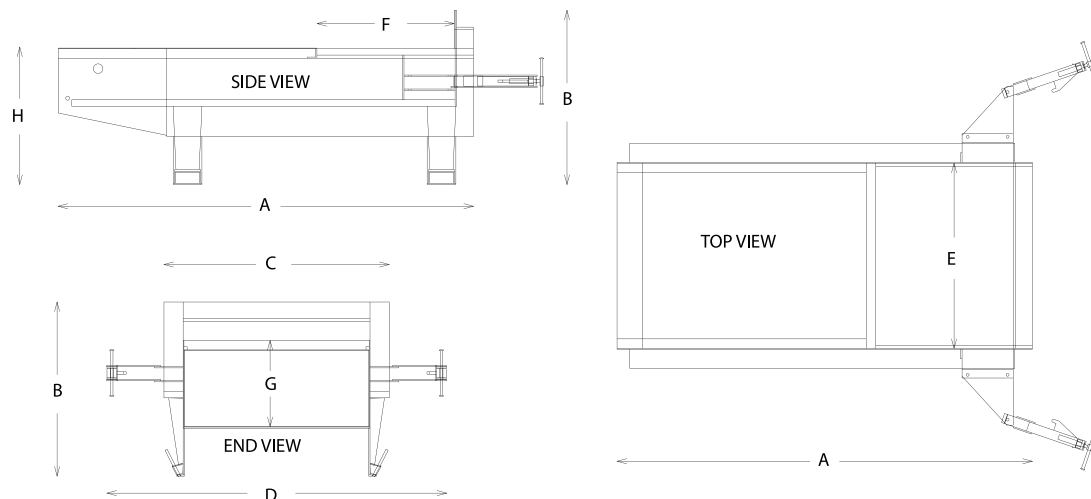

Canada's leading manufacturer of waste compaction and recycling equipment





DESIGNED FOR MODERATE DUTY SERVICE, Rotobale's 4260 stationary compactor is ideal for light industrial plants, retail/grocery stores, hospitals and many more similar applications.

AVAILABLE IN VARYING SIZES, the C-series line of stationary compactors have been designed for heavy industrial duty service. These systems are ideal for manufacturing facilities and heavy industrial plants, or other similar applications.

Product Features:

- **14" - 18" RAM PENETRATION** within the container, the most in the industry
- **SMALLER RAM FACE** delivers increased compaction force
- **RAM DWELLS AGAINST THE LOAD** increasing compaction & maximizing container capacity
- **MODEL 4260 CROSS CYLINDER** design is ideal for tight spaces allowing for a steeper chute
- **43" FEED HEIGHT** designed for easy accessibility
- **EASY TO USE CONTROL PANEL** comes standard with key start, full light, and emergency stop button
- **MANUFACTURER'S SAFETY DECLARATION**

Customized Feed Applications:

ROTOBALE COMPACTION SOLUTIONS INC.



Walk-on Weather Enclosure



Walk-on Weather Encl. Interior



Weather Enclosure with Side Chute



Rear Wall Chute



Walk-on Deck with Safety Railing



Hinged Door Hopper



Open Hopper with Access Door



Rear Counter Balance Lid



Enclosed Hopper with Cart Dumper



Retractable Manual Crank Chute